Fundamentals of Measurement Transducers and Synchronizers

Course No: E03-031

Credit: 3 PDH

Velimir Lackovic, Char. Eng.



Continuing Education and Development, Inc.
22 Stonewall Court
Woodcliff Lake, NJ 07677

P: (877) 322-5800
info@cedengineering.com

FUNDAMENTALS OF MEASUREMENT TRANSDUCERS AND SYNCHRONIZERS

The precise measurement of the voltage, current or other power system parameters is a requirement for any automation and control process, ranging from automatic closed-loop control to the information sampling for statistical needs. Measurement of these quantities can be achieved in a different ways, including the application of direct-reading devices as well as electrical measuring transducers. There is a wide range of measurement instruments that are used to gather information and convert it into information that can be used by the operator. Typically, the instruments are classified depending on possibility for local or remote application.

TYPICAL TRANSDUCER FEATURES

Transducers generate precise DC analogue output, typically a current, which corresponds to the measures value. They also give electrical isolation by instrument transformers, which is frequently referred to as 'Galvanic Isolation' and they are located between the input and the output. This is safety characteristic, however cables from the output points to any receiving devices can be minimized and have a lower insulation specification. The benefits over discrete measuring devices are as follows:

- placed close to the measurement source, decreasing instrument transformer burdens and improving safety by avoiding long wiring runs
- possibility to install display devices remotely from the transducer
- possibility to use several displays per transducer
- the burden on CTs/VTs is significantly lower

Transducers outputs may be utilized in many forms – from simple presentation of measured quantities for an operator, to being used by a power network automation center to select the control strategy. Transducers may have one or more inputs and/or outputs. The inputs, outputs and any auxiliary connections are isolated from each other. There may be more than one input value and the measured quantity may be a function of one or more of them. Regardless of the used measurement transducer, there will typically be a selection between discrete and modular types. The modular type is typically plug-in unit to a standard rack. The position and user-requirements will dictate the transducer type selection.

TRANSDUCER INPUTS

Transducer input is typically taken from transformers. These inputs can come in many different formats. Ideally, to achieve the best precision, metering-class instrument transformers need to be utilized since the transformer errors will be added, albeit algebraically, to the transducer errors. Nevertheless, it is frequent to use transducers to protection-class instrument transformers and from that reason transducers are typically selected so that they can withstand significant short-term overloads on their current inputs. Typically, transducer appropriate for connection to protection-class instrument transformers should withstand:

- 300% of full-load current continuously
- 2500% of full-load for three seconds
- 5000% of full-load for one second

The input impedance of current input circuit should be minimal. The input impedance of voltage input circuit should be maximized. This eliminates errors due to impedance mismatch.

TRANSDUCER OUTPUTS

Transducer output is typically a current source. This implies that, within the transducer output voltage range, display elements can be installed without limit and without any need for transducer adjustment. Compliance voltage sets the output circuit maximum loop impedance, so a compliance voltage high value allows remote installation of an indicating instrument. In situations, when the output loop is utilized for control purposes, suitably sized Zener diodes are typically fitted across the terminals of each of the elements in the series loop to protect against the possibility of their internal circuitry becoming open circuit. This assures that a faulty instrument in the loop does not cause overall failure of the output loop. The transducer output constant current nature simply increases the voltage and continues to drive the precise output signal round the loop.

TRANSDUCER PRECISION

Typically, accuracy is of great importance. However it has to be noted that accuracy can be specified in few ways and may only apply under specified application conditions. Terminology presented in IEC 60688 clarifies typical terms and relates them to practical application. The transducer accuracy will be impacted, to a higher or lesser extent, by many components, known as influence factors. User has little or no control over them. Complete list of influence factors is provided in Table 1. The accuracy is verified under an agreed set of circumstances known as reference conditions. The reference conditions for each of the influence factors can be cited as a single value (e.g. 25°C) or a range (e.g. 10-50°C).

Table 1. Transducer influence factors

Input current and voltage	Common mode interference
Input quantity distortion	Input quantity frequency
Power factor	Unbalanced currents
Interaction between measuring elements	Ambient temperature, self-heating and external heat
Auxiliary supply voltage	Auxiliary supply frequency
External magnetic fields and series mode interference	

Error calculated under reference circumstances is known as the intrinsic error. All transducers that have exactly the same intrinsic error are organized in special accuracy group which is labeled with the class index. The class index is exactly the same as the intrinsic error presented as a percentage (e.g. a transducer with an intrinsic precision of 0.2% of total scale has a class index of 0.2). The class index classification utilized in IEC 60688 demands that the change for each of the influence parameters be precisely related to the intrinsic error. This means that the greater the accuracy presented by the producer, the changes must be lower. Because there are numerous influence factors, the changes are separately analyzed, whilst keeping all the other influence factors at reference conditions. The nominal range of transducer usage is the typical transducer operating range as defined by the producer. The nominal application range will be wider than the reference value or range. Within the nominal transducer application range, additional errors add up. That results in an extra error. This extra error is limited for any particular influence factor to, at most, the value

of the class index. Table 2 presents performance characteristics of a common transducer range (accuracy class 0.5).

Table 2. Common transducer characteristics

Influence Factor	Reference Range	Max. Error-Reference Range %	Nominal Operating Range	Max. Error-Nominal Range
Input frequency	45...65Hz	0.5%		
Power factor	$\cos \varphi = 0.5 \dots 1$	0.25%	$\cos \varphi = 0 \dots 1$	0.5%
Unbalanced current	0...100%	0.5%	-	-
Aux. supply DC voltage	24...250V DC	0.25%	19V-300V	0.25%
Input Voltage, V_n	$V_n=50\dots500V$ 80...120%	0.25%	0-120%	0.5%
Self-Heating	1...30 min	0.5%	-	-
Output load	10...100%	0.25%	-	-
Waveform crest factor	1.41 (sine wave)	-	1.2...1.8	0.5%
Ambient temperature	0°-50° C	0.5%	-10°-60°C	1.0%
Continuous operation	Continuous >6h	0.5%	-	-
Output common mode interference	100V 50Hz RMS output to earth	0.5%	-	-
AC Aux. Supply frequency, f_n	90...110% f_n	0.25%	-	-
External magnetic fields	0...0.4 kA/m	0.5%	-	-
Output series mode interference	1V 50Hz RMS in series with output	0.5%	-	-
Input current, I_n	$I_n=1A,5A$ 20...120%	0.5%	0-120%	0.5%

Misunderstandings happen in defining the operation under real service conditions. The output signal is typically a D.C. analogue of the measurand, but is found from alternating input factors and will usually contain alternating part, or ripple. Ripple is specified as the peak-to-peak measure of the alternating portion of the output signal even though some producers quote 'mean-to-peak' or 'r.m.s.' values. The conditions under which the quantity of the ripple has been measured must be presented, e.g. 0.35% r.m.s. = 1.0% peak-to-peak ripple. Under varying conditions of the measurand,

the output signal does not instantly follow the variations but is time delayed. This happens due to the filtering needed to decrease ripple or, in numerical transducers, stop aliasing. The degree of delay is known as the response time. To a certain limit, ripple and response time are related. The response time can typically be decreased at the expense of increased ripple, and vice-versa. Transducers with shorter response times than normal can be provided for those situations where the power system goes through dips, swings, and low frequency oscillations that have to be supervised. Transducers with current output have a maximum output voltage that is known as the compliance voltage. If the load resistance is great and therefore the compliance voltage is surpassed, the transducer output is no longer precise. Few transducers are qualified by the manufacturer for use on power systems where the waveform is not a pure sinusoid. They are known as 'true r.m.s. sensing' transducer types. For these types, the waveform distortion factor is an influence factor. Other transducers are known as 'mean-sensing' and are made to react to the r.m.s. quantity of a pure sine wave. If the input waveform gets distorted, errors will happen. For instance, the error due to third harmonic distortion can equal to 1% for every 3% of harmonic. Once set up, the user anticipates the transducer accuracy to stay constant over time. The application of high quality elements and conservative power ratings will help to provide long-term stability, but different circumstance at site can cause performance variations that may need to be compensated for during the equipment lifetime.

DIGITAL TRANSDUCER PRINCIPLES

Digital power system transducers use the same technology as digital and numerical protection relays. The analogue signals obtained from VTs and CTs are filtered to prevent aliasing, converted to digital form using A/D conversion, and then signal processing is used to extract needed data. Sample rates of 64 samples/cycle or higher can be applied, and the accuracy class is typically 0.2 or 0.5. Outputs can be both digital and analogue. The analogue outputs will be impacted by the factors affecting accuracy. These factors are described above. Digital outputs are commonly in the form of a communications link, with RS232 or RS485 serial. Also RJ45 Ethernet connections are typically available. The response time may decrease in comparison to analogue transducers, depending on the rate at which information is transferred to the communications link and the delay in processing information at the receiving end.

As a matter of fact, all of the influence factors that impact a common analogue transducer are also present in a digital transducer in some form. However, the final errors may be lesser than in an analogue transducer and it may be more stable over a long period of time. The benefits of a transducer with numerical technology are:

- enhanced long-term stability
- more precise r.m.s measurements
- enhanced communications facilities
- programmability of scaling
- wider range of features
- minimal size

The enhanced long term stability cuts down costs by extending re-calibration intervals. More precise r.m.s measurements give the user improved accuracy data, particularly on supplies with substantial harmonic content. The enhanced communications facilities allow many transducers to use the same communications link, and each transducer to give few measurements. This decreases necessary interconnecting wiring and number of transducers. Remote or local programmable scaling of the transducer allows scaling of the transducer at the site. The scaling can be modified to reflect modifications in the power system, or to be re-applied elsewhere. Modifications can be obtained via the communications link, therefore eliminating the requirement for a site visit. It also eliminates the risk of the user defining an incorrect scaling factor and having to return the transducer to the producer for modification. Suppliers can maintain a wider range of transducers suited for a wide range of usages and inputs in stock, therefore cutting down delivery times. Transducers are available with a greater range of features in one package, therefore decreasing space requirements in a switchboard. Available characteristics include harmonics up to the 31st, energy, and maximum demand. The third one is practical for tariff agreements.

ANALOGUE TRANSDUCER PRINCIPLES

All analogue transducers have the following basic characteristics:

- an input circuit having impedance Z_{in}
- isolation (no electrical link) between input and output

- an ideal current source producing an output current, I_1 , which is precise and linear function of Q_{in} , the input value
- a parallel output impedance, Z_0 . This presents the real output impedance of the current source and shunts a small part, I_2 , of the ideal output
- an output current, I_0 , equal to $(I_1 - I_2)$

These characteristics are presented in Figure 1.

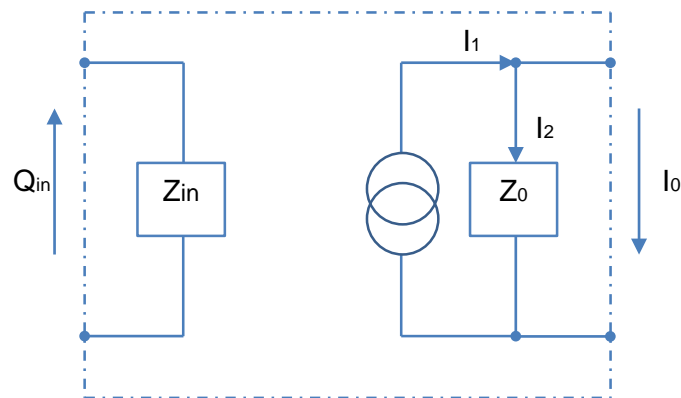

Figure 1. Analogue transducer diagram

Output ranges of 0-10 mA, 0-20 mA, and 4-20 mA are typical. Live zero (e.g. 4-20 mA), suppressed zero (e.g. 0-10mA for 300-500kV) and linear inverse range (e.g. 10-0mA for 0-15kV) transducers typically need an auxiliary supply. The dual-slope model has two linear parts to its output characteristic, for instance, an output of 0-2 mA for the first portion of the input range, 0-8 kV, and 2-10 mA for the second portion, 8-15kV.

TRANSDUCER CHOICE

The choice of the adequate transducer to complete a measurement function depends on many components. These components are described below.

CURRENT TRANSDUCERS

Current transducers are typically connected to the secondary of an instrument current transformer with a nominal output of 1 or 5 amps. Mean-sensing and true r.m.s. models are available. If the waveform comprises substantial harmonics quantities, a true r.m.s sensing model must be applied for precise measurement of the input. They can be

self-powered, except for the true r.m.s. models, or when a live zero output (for example 4-20 mA) is needed. They are not directional and, hence, are unable to recognize 'export' and 'import' current. To get a directional signal, a voltage input is also needed.

VOLTAGE TRANSDUCERS

Connection is typically to the secondary of an instrument voltage transformer but can be also direct if the analyzed value is of sufficiently low voltage. The suppressed zero model is typically utilized to give an output for a specific range of input voltage where measurement of zero on the input value is not needed. The linear inverse model is usually utilized as assistance to synchronizing.

FREQUENCY

Precise frequency measurement is of critical importance to transmission system operators but not quite so critical, for the operator of a diesel generator set. Accuracy classes of 0.1% and 0.01% can be used based on percent of center scale frequency. This implies that equipment labeled as 0.1% and having a scale figure of 50Hz will have a maximum error of +/- 50 mHz under reference conditions.

PHASE ANGLE

Phase angle measurement transducers are typically utilized for the display of power factor. This is accomplished by scaling the indicating device in a non-linear manner, following the cosine law. For digital indicators and SCADA devices, it is mandatory for the receiving device to allow for adequate conversions to accomplish the precise display of power factor. Phase angle transducers are manufactured with different input ranges. In the case of $-180^{\circ} \dots 0^{\circ} \dots 180^{\circ}$ scaling range, there is an ambiguous area, of about $\pm 2^{\circ}$ at the range extremes. In this area, where the output is anticipated to be, for instance, -10mA or $+10\text{mA}$, the output may jump sporadically from one of the full-scale values to the other. Transducers are also manufactured for the measurement of the angle between two input voltages. Some phase angle transducer models utilize the zero crossing point of the input waveform to get the phase data and are therefore prone to error if the input has substantial quantities of harmonics. Computing the power factor from the outputs of a Watt and a Var transducer will provide correct measurement even with harmonics.

POWER MEASUREMENTS

Active power (watts) and reactive power (vars) measurement is usually not simple as measurement of other factors. More attention has to be taken due to the variety of arrangements. It is vital to choose the adequate measurement method by considering factors such as system working conditions (balanced or unbalanced load), the number of current and voltage connections and if the power flow is predominantly 'import', 'export', or both. The range of the measurand has to cover all needed possibilities of over-range under normal working conditions so that the transducer and its indicating device, or other receiving device, is not utilized above the upper limit of its defined range. Figure 2 shows different measurement type arrangements.

SCALING

The relationship of the output current to the quantity of the measurand is of crucial importance and has to be carefully considered. Any receiving device has to be utilized within its nominal rating however some kind of standard should be laid down. For example, consider the measurement of A.C. voltage. The primary electrical system has a nominal value of 11kV and the transformer has a ratio of 11kV/110V. Defining voltage transducer conversion coefficient to 110V/10mA would not necessarily be the optimal choice. One of the goals has to be the capability of monitoring the voltage over a range of figures so an upper limit has to be chosen – for example +20%, or 132V. Using the original conversion coefficient, the maximum transducer output has to be 12mA. This is within the capacity of most 0-10mA transducers. Majority of them can allow for an over-range of 25%, but it also means any related analogue indicating device needs to have a sensitivity of 12mA. Nevertheless, the scale needed on this device is now 0-13.2kV, which may lead to problems in drawing the scale in such a way as to make it clear. In this instance, it would be easier to define the full-scale indication as 15kV and to make this same to 10mA, therefore making the specification of the display device much easier.

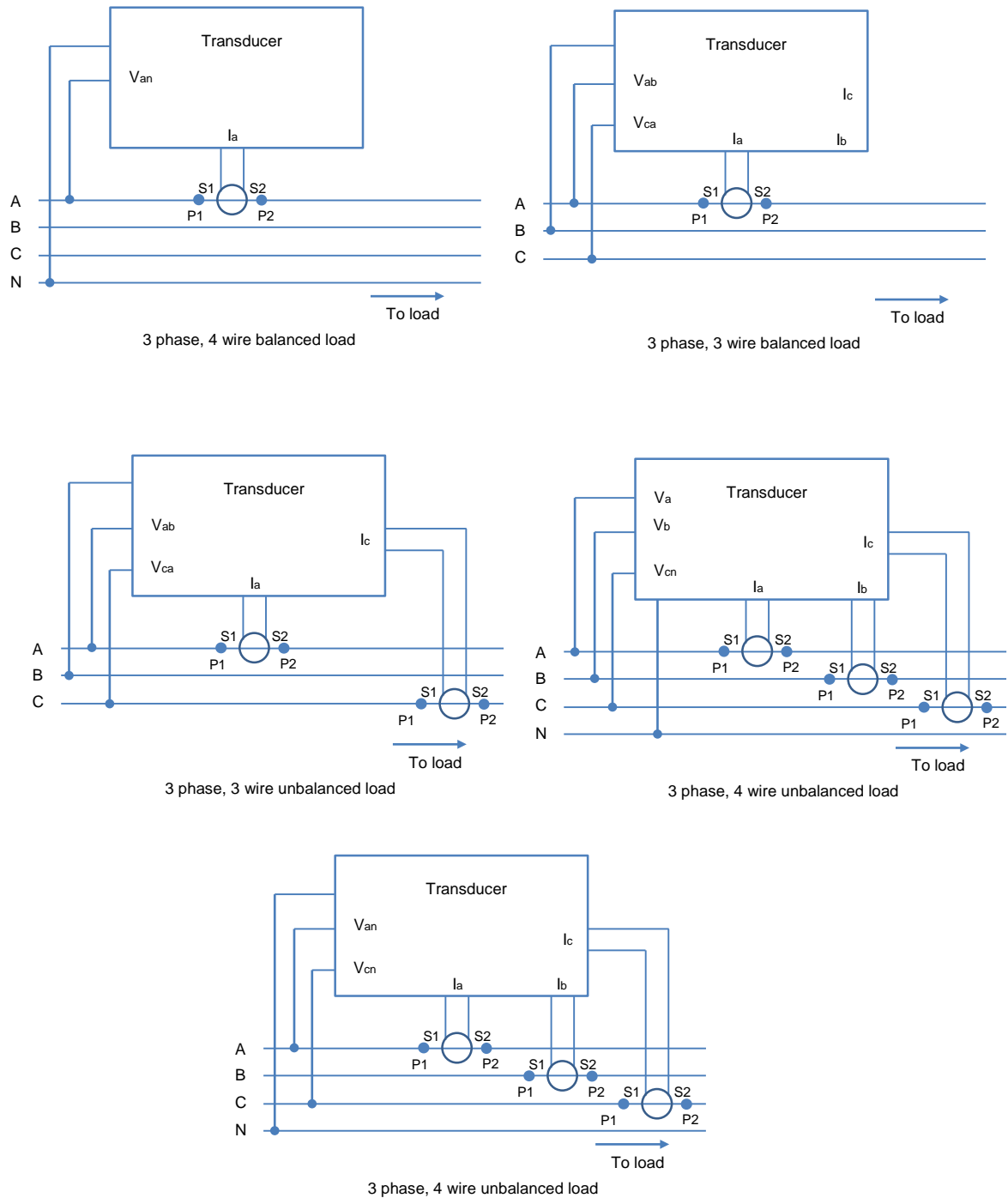

Figure 2. Connection arrangements for 3-phase watt/VA transducer

The transducer will have to be defined in a way that an input of 0-150V provides an output of 0-10mA. In the situations of 4-20mA output transducers, great attention is needed in the output scaling, as there is no over-range capacity. The 20mA output limit is a determined from a measurement point of view. Such outputs are commonly utilized as SCADA systems inputs, and the SCADA system is usually programmed to

presume that a current magnitude in surplus of 20mA presents a transducer fault. Also, a reading below 4mA suggests a fault, typically an open circuit in the input connection. Therefore, using the above example, the output could be scaled so that 20mA presents 132V and therefore the nominal 110V input leads to an output of 16.67mA. A more appropriate scaling might be using 16mA representing 110V, with 20mA output being equal to 137.5V (i.e. 25% over-range instead of the 20% needed). It would not be correct to scale the transducer so that 110V input was represented by 20mA output, as the needed over-range capacity would not be available.

Similar conditions apply to current transducers and, with additional complexity, to watt transducers. In their case the ratios of both the voltage and the current transformers has to be considered. In this case, the output will be associated with the primary system power. It has to be noted that the input current matching full-scale output may not be precisely same to the secondary rating of the current transformer. Some of these issues do not need to be studied if the transducer is only feeding, for instance, a SCADA outstation. Any receiving device that can be programmed to use a scaling factor to each input can fit most input signal ranges. The primary consideration will be to make sure that the transducer has the capacity to provide a signal right up to the full-scale value of the input. It must not saturate at the greatest anticipated value of the measurand.

AUXILIARY SUPPLIES

Few transducers do not need any auxiliary supply. These transducers are known as 'self-powered'. Those that require a separate supply, usually have a biased, or live zero output, such as 4-20mA. This is because a non-zero output cannot be got for zero input unless a dedicated supply is available. Transducers that need an auxiliary supply are usually equipped with a dedicated pair of terminals for the auxiliary circuit so that the user has the possibility of linking the auxiliary supply input to the measured voltage, or to a dedicated supply. Nevertheless, some producers have standardized designs so that they seem to be of the self-powered models, but the auxiliary supply link is internal. For A.C. measuring transducers, the application of a D.C. auxiliary supply allows the transducer to be controlled over a greater range of input. The range of auxiliary supply voltage over which a transducer can be controlled is defined by the

producer. If the auxiliary voltage is deduced from an input measure, the range of measurement will be limited to around +/-20% of the rated auxiliary supply voltage. This can increase issues when trying to measure low values of the input signal.

MEASUREMENT CENTERS

A measurement center is different from a transducer in following ways:

- It has various communication forms to transfer information ranging from simple pulsed contacts to numerous digital communication ports
- It can measure a great number of instantaneous factors, and with an internal clock, compute time based factors such as maximum demand
- It is equipped with a local display so that data, system status and alarms can be presented to the operator.

This is not practical if analogue signal processing methods are used, but no such limitation exists if digital or numerical methods are used. Hence, measurement centers are commonly using these signal processing methods. Numerical protection relay can give numerous power system quantities measurements. Hence, an additional way of looking at a measurement center that utilizes numerical technology is that it is a numerical protection relay, stripped of its protection features and integrating a great range of power system parameter measurements.

This is an oversimplification of the actual situation, as there are some crucial differences. A protection relay has to give the primary function of protection over a great range of input quantities; from perhaps 5% to 500% or even more of nominal values. Although important, the measurement precision is not needed to be as precise as metering for tariff needs. Metering does not have to cover such a great range of input quantities, and hence the precision of measurement is usually needed to be greater than for a protection relay. Additional features over that given by the protection relay measurement functions are usually needed. A common set of features provided by a measurement center is provided in the Table 3. Then again, the basic measurement process in a measurement center based on numerical methods is identical to that of a numerical protection relay, so need not be repeated here. The only differences are the ranges of the input signals and the functionality. The former

is addressed with appropriate arrangement of the input signal conditioning and A/D conversion, the latter is addressed with given software.

Table 3. Common feature set given by a measurement center

Average current	Average voltage
Neutral current	RMS phase voltages
Demand current in period	Demand power in period
RMS line currents	RMS line voltages
Negative sequence voltage	Negative sequence current
Power	Reactive power
%THD (current)	Programmable multiple analogue outputs
Apparent power	Power factor
Phase angle (voltage/current)	Demand time period
Maximum demand (W and var)	Energy, Wh
Individual harmonics (to 31 st)	%THD (voltage)
Demand reactive power in period	Demand VA in period
Demand power factor in period	Maximum demand current
Energy, Varh	Frequency

The benefits of a measurement center are that a comprehensive set of features are given in a single item of equipment, consuming little extra space in comparison with discrete transducer for a much smaller number of parameters. Hence, when the required CTs and VTs are present, it may make sense to use a measurement center even if not all functions are instantly needed. Practice shows that more and more information is needed as time goes, and incorporation of complete functionality at the outset seems logical. Typical transducer is shown in Figure 3.



Figure 3. Typical transducer

TARIFF METERING

Tariff metering is a particular measurement process, related to the measurement of electrical power, reactive power or energy for the needs of billing the consumer. It has to adapt to the relevant national standards for such issues. Primary tariff metering is utilized for customer billing needs, and may require a measurement precision of 0.2% of reading, even for readings that are 5% or less of the rated quantity. Secondary tariff metering is used where the user wants to incorporate additional metering as verification on the primary tariff metering provided by the supplier, or within a huge plant or building to get exact picture of the energy consumption in different areas. These findings can be used for the purpose of energy audits or internal cost allocation. The precision of such metering is lower, typical accuracy of 0.5% over a great measurement range being usually needed. As this is the completely required accuracy, each device in the metering chain (starting with the CTs/VTs) must have greater accuracy than this. Special care to wiring and mounting of the transducer is needed to avert errors due to interference, and the precision may need to be kept over a wide frequency range. Hence, a tariff metering arrangement needs special design of all of the devices included in the scheme. Additional facilities are typically provided to allow measurements over a huge number of defined time periods (e.g. 24 half-hour periods for generator energy tariff metering) so that the energy exporter can generate total invoice for the user according to the defined rates for each tariff period. The time intervals that these periods cover may vary according to the time of year (winter, spring, etc.) and hence programming flexibility of the energy metering is needed. Remote communications are needed, so that information is transferred to the relevant department on a regular basis for invoicing needs.

For primary tariff metering, data security is a great design criterion. Meters also contain tamper-proof physical indication.

SYNCHRONIZERS

Synchronizers are needed at power system locations where two supplies (either generator and grid, or two grid supplies) may have to operate in parallel. They are more than just measuring equipment. They allow circuit breaker to close when criteria

for paralleling (synchronizing) are met. There are two types of synchronizers - auto-synchronizers and check synchronizers.

CHECK SYNCHRONISERS

The purpose of a check synchronizer is to find out if two voltages are in synchronism and give outputs under these conditions. The outputs are typically in the form of volt-free contacts, so that they may be utilized in circuit breaker control circuits to allow or block circuit breaker closing. The check synchronizer is applied to verify that it is safe to close a circuit breaker in order to connect two independent networks, or a generator to a network. This function is demonstrated in Figure 4. In this way, the check synchronizer executes a crucial function in blocking circuit breaker closure.

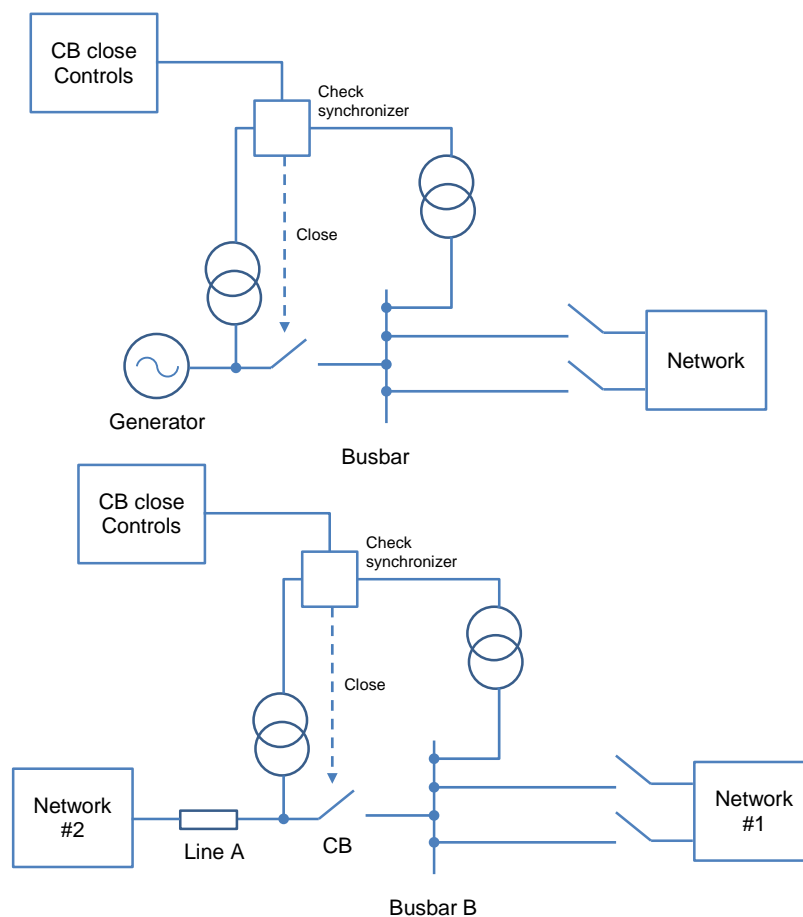

Figure 4. Check synchronizer usages (a) Application to generator (b) Application to two separate networks

Synchronism happens when two A.C. voltages are of the same frequency and amplitude, and have zero phase difference. Once activated, the check synchronizer, monitors these values and enables circuit breaker close circuits when the differences are within pre-set limits. While circuit breaker closure at the time of perfect synchronism is preferred, this is very challenging to achieve in reality. Certain mismatch in one or more of the monitored values can be tolerated without leading to great current/voltage transients. The check synchronizer comprises programmable error limits to specify the limits of acceptability when making the comparison. The conditions under which a check synchronizer is needed to give an output are varied. Consider the case of a check synchronizer applied as permissive equipment in the closing control circuit of a circuit breaker that joins together two transmission networks. It is not enough to assume that both transmission networks will be live. Cases where either Line A or Busbar B may be out of service may have to be assessed, leading to the functionality presented in Table 4.

Table 4. Synchronizer operation set

Check synchronizer functionality	
CB closing advance time	CB closing pulse time
Dead bus/live line synchronizing	Network supply voltage #1 deviation from nominal
Network supply voltage #2 deviation from nominal	Voltage difference within limits
Live bus/live line synchronizing	Live bus/dead line synchronizing
Frequency difference within limits	Phase angle difference within limits
Maximum number of synchronizing attempts	
Additional functions for auto-synchronizer	
Voltage raise/lower pulse time	Frequency raise/lower pulse time
Incoming supply voltage setpoint	Incoming supply frequency setpoint
Incoming supply voltage raise/lower mode (pulse/continuous)	Incoming supply frequency raise/lower mode (pulse/continuous)
Incoming supply frequency deviation from nominal	Incoming supply voltage raise/lower signal

When the close signal is allowed, it may be provided only for a limited time period, to decrease the chances of a circuit breaker close signal remaining after the conditions have shifted outside of limits. Likewise, circuits may also be supplied to block closure if the circuit breaker close signal from the circuit breaker close controls is present prior to acceptable conditions— this guarantees that an operator has to monitor the

synchronizing displays and initiate closure only when synchronizing conditions are met. It also notices synchronizing switch contacts that have become welded together. A check synchronizer does not start any readjustments if synchronizing conditions are not met. Hence, it acts as a permissive control in the complete circuit breaker closing circuit to give a check that conditions are acceptable. In a substation, check-synchronizers may be separately used to all required circuit breakers. Instead, a smaller number may be incorporated, together with particular switching design in the signal input/output circuits, so that single equipment may be chosen to cover few circuit breakers.

AUTO-SYNCHRONIZER

An auto-synchronizer comprises extra features in comparison to a check synchronizer. When an auto-synchronizer is put in operation, it measures the frequency and amplitude of the voltages on both sides of the circuit breaker, and automatically adapts one of the voltages if criteria are not correct. Auto-synchronizers usage is typically limited to generators – i.e. the situation presented in Figure 4, replacing the check synchronizer with an auto-synchronizer. Usually it is not possible to adapt one of the network voltages by modifying the settings of one or several elements in a power network. When applied to a generator, it is quite simple to adapt the frequency and magnitude of the generated voltage by transferring signals to the governor and AVR respectively. The auto-synchronizer will verify the voltage of the incoming generator against the transmission network voltage for conformity with the following:

- slip frequency within limits (i.e. frequency variation between the generator and transmission network)
- voltage amplitude difference within limits
- phase difference between the voltages within limits

The circuit breaker close command is automatically sent when all three considerations are met. Verifications may also be made that the transmission network frequency and voltage is within pre-set range, and if not the synchronizing sequence is locked out. This stops synchronizing under unusual network situations, when it may not be desirable. This feature should be applied with care, since under some emergency situations; it could stop the synchronizing of a generator that was urgently needed in

operation. If slip frequency is not within limits, signals are automatically transferred to the governor of the generating set to adequately adapt the speed set point. In the case voltage amplitude difference is not within the limits, similar signals are transferred to the Automatic Voltage Regulator (AVR) to increase or decrease the set point. The signals are typically in the form of pulses to increase or decrease the set point, but could be also continuous signals if that is what the particular devices need. It is common for the generator speed and voltage to be somewhat higher than those in the network, and this can be adapted either by initial settings on the Governor/AVR or by putting set point values in the synchronizer. This guarantees stable synchronizing and power export at lagging power factor to the transmission network after circuit breaker closure. Application of an auto-synchronizer also assists in avoiding human error. If manual synchronizing were used – there is potential for damage to device, mainly the generator, if synchronizing outside of permitted limits happens.

To assure that the circuit breaker is closed at the correct moment, the circuit breaker close time is typically a required data point. The auto-synchronizer computes the correct time of phase co-incidence to send the circuit breaker close command. This assures that the circuit breaker closes as close to the instant of phase co-incidence as possible. Upon reception of the signal showing 'circuit breaker closed' additional signal to increase frequency may be sent to the governor to secure stable export of power. Failure of the circuit breaker to close within a set time period will reset the auto-synchronizer. It will get ready for next attempt, and if next attempts are still unsuccessful, the auto-synchronizer will shut down and raise an alarm.

Auto-synchronizers fitting differ between utilities. Many utilities rely on manual synchronizing methods. It is also possible that auto-synchronizer and check-synchronizer are fitted in series. This gives protection against internal auto-synchronizer fault. This fault could lead to a circuit breaker close command being incorrectly sent.

DISTURBANCE RECORDERS

Power systems experience various disturbances. In post-fault assessment, it is useful to have a comprehensive record of a disturbance. That allows the starting event to be

distinguished from the subsequent effects. Particularly in cases when the disturbance causes additional problems (e.g. single-phase failure develops into 3-phase), a comprehensive fault recording may be needed to distinguish between cause and result. If the fault effects are located over a wide area, disturbance records from a number of locations can help in finding out disturbance location. The device used for this application is known as a disturbance, or fault, recorder.

DISTURBANCE RECORDER CHARACTERISTICS

A disturbance recorder will typically have the following features:

- multi-channel analogue input waveform recording
- recording time of few seconds per disturbance
- time synchronization (IRIG-B, GPS, etc.)
- varying pre/post trigger recording length
- distance to fault location for one or more transmission lines
- programmable sampling rates
- triggering from any analogue or digital input channel, or quantity deduced from a combination of inputs, or manually
- standard data transfer formats
- multi-channel digital input recording
- storage of few fault records, ready for download/assessment
- communication links to control center (Ethernet, modem, etc.)
- self-monitoring and diagnostics

Analogue channels are used to record the crucial currents and voltages at the fault recorder location. High resolution is needed to ensure precise capture of the waveforms. 16 bit A/D conversion is typical. Digital inputs are used to catch signals such as circuit breaker opening, protection relay functioning and intertrip signals so that an overall picture of the sequence of events can be made.

The data can then be processed to verify that the post-fault operation sequence is adequate, or help in finding out the cause of an unexpected sequence of actions. To prevent loss of the disturbance information, adequate memory is used to collect and store the information from few faults prior to transfer of the data for assessment.

Flexibility in the triggering arrangements is crucial, as it is pointless to put in a disturbance recorder, only for it to miss disturbances due to lack of adequate triggering facilities. It is common for triggering to be available if the applicable threshold is crossed on any analogue or digital channel, or a value deduced from a combination of the inputs.

Power system disturbances may last from cycles to several minutes. To assure that maximum benefit is got from the investment, a disturbance recorder has to be able to catch disturbances over a wide range of timescales. This heads to the provision of programmable sampling rates, to assure that short-term transients are caught with adequate resolution. They also need to assure that longer-term transients are sufficient in order to enable a meaningful assessment. The record for each disturbance is broken down into sections covering pre-fault, fault, and post-fault periods. Each of these periods may have different sampling rates. Time synchronization is also a critical characteristic since it needs to enable a recording from one disturbance recorder to be aligned with another. This should help to get a complete picture of events. Since majority of disturbance recorders are placed in unmanned substations, the provision to download collected data is essential. Each fault recording will contain a large amount of information, and it is crucial that the information is precisely described in respect of recorder, fault event, channel, etc. Standards are used to assist data interchange. Probably the best known is the IEEE COMTRADE format. It is now available as an international standard (IEC 60255-24). Once downloaded, information from a disturbance recorder can be assessed with different PC software packages. The software usually has the capability to complete harmonic and other assessments.